

TV filters

TYPES

BF4-3C500
BF4-4C500
BF4-4C100D-N
BF4-6C500
BF4-6C100D-N
BF4-3C1K0
BF4-4C1K0
BF4-4C250D-N
BF4-6C1K0
BF4-6C250D-N
BF4-4C1K7
BF4-4C2K1-HS
BF4-4C3K5
BF4-4C4K0-HS
BF4-4C13K-LC
BF4-4C7K0
BF4-4C9K0-HS
BF4-4C20K-LC
BF4-6C130D-N
BF4-7C130D-C
BF4-6C250D-N
BF4-7C250D-C
BF4-6C550D-N
BF4-6C700D-N-HS
BF4-6C550D-C
BF4-6C700D-C-HS
BF4-8C500D-C
BF4-8C600D-C-HS
BF4-6C1K1D-N
BF4-6C1K5D-N-HS
BF4-6C1K1D-C
BF4-6C1K5D-C-HS
BF4-8C1K0D-C
BF4-8C1K3D-C-HS
BF4-6C2K5D-N
BF4-6C7K5D-N-LC
BF4-6C2K5D-C

Band-pass filters are used to attenuate frequencies outside a narrow pass-band. They are commonly used as components in the design of combiners, for the attenuation of noisy side bands, to achieve additional decoupling between transmitters installed in close proximity in the same antenna system, and to combine digital channels with existing analogue channels.

The band-pass filters are factory tuned to the desired operating channels. All filters are retunable on whole frequency bands III (VHF) and bands IV and V (UHF).

Band-pass filters consist of 3, 4, 6, 7 or 8 magnetic coupled coaxial resonators with adjustable coupling. One end of the resonator is open-circuited and the other short-circuited and tuning is accomplished by rotating the circular central conductor at the lower end of each resonator. The coaxial input and output lines are coupled to the first and last resonator by magnetic coupling loops.

ELTI critical mask filters for digital operation are 6, 7 and 8 cavity filters with elliptical response to satisfy critical mask requirements or adjacent channel configuration for DVB, ISDB-T and ATSC standards. Critical mask filter with 6 cavities are generally used with ELTI transmitters only.

Main advantages of these filters are:

- foreshorten folded combline design,
- iris couplings with fine bandwidth regulation,
- retunable on whole frequency bands III, IV and V.

Filters are part of ELTI complete solutions:

- transmitter TERX, as output filter available on request,
- regenerative repeater ARX, as output filter available on request,
- combiners for adjacent channel configuration and/or non-critical & critical mask requirements.

Operating Power

The maximum operating power of a filter is limited by heating and peak voltage.

Heating is caused by high currents on resonators and are the main cause of dissipation due to Joule effect. Other secondary causes are the dissipations in the remaining circuit elements and in the dielectrics. To reduce losses, particularly at high frequencies, the conducting surfaces need to be excellent conductors. An accurate analysis of dissipations conducted using electromagnetic simulations makes it possible to optimize the construction for minimal loss.

The peak voltage represents the absolute power limit of a filter. The possibility of a breakdown occurring is related to the dielectric rigidity and the various ambient conditions (temperature, humidity and pressure). An accurate analysis of the breakdown limits requires specific electromagnetic and circuit simulations. All ELTI filters are designed for a voltage safety factor of at least 2 at the maximum rated power.

In specifications are stated power in rms (digital mode) and p.s. (analogue mode) for 8 MHz channel (UHF) and 7 MHz (VHF). Filters for digital operation can be used for analogue or dual cast mode. Use multiplier 1,5 of rms power to calculate peak sync power. For digital 7 MHz channel use multiplier 0,9 and for 6 MHz channel multiplier 0,75.

Operating temperature

All ELTI filters are designed to operate in severe environmental conditions such as -5 to +55 °C, as expected inside a typical transmitter operating in a standard environment (EN 300 190, Class 3.1). In these conditions, the maximum temperature raise is specified for each filter (typically < 40 °C). For safety reasons, and for optimum performances and filter's lasting, the maximum filter's body temperature should never exceed 70°C, and the recommended operating temperature limit is 60°C.

The operation at the maximum rated power generally requires some cooling:

- conventional cooling,
- conventional cooling with heat sinks added on the top of the filter,
- UHF high power filters can be optionally equipped with a state-of-the art water cooling circuit, to be inserted in liquid cooled transmitters.

Type of cooling is given in specifications. Extremely low temperatures (< -15 °C) should be avoided, as they could deteriorate the filters due to excessive thermal shocks, primarily during the transient warm-up.

Passive Intermodulation

All of the passive components involved with digital signals must possess a very high degree of linearity, to prevent Passive Inter Modulation (PIM). All ELTI passive components are designed and fully meet the typical PIM < -153 dBc requirement.

Electrostatic Protection

All ELTI filters have an adequate electrostatic protection on input / output connectors, i.e. the inner terminals are electrically connected to ground (DC short circuit), with a current capacity always much higher than the one of the connector itself.

TYPES

BF4-6C7K5D-C-LC
BF4-8C2K5D-C
BF4-8C7K5D-C-LC
BF4-6C5K0D-N
BF4-6C12K5D-N-LC
BF4-6C5K0D-C
BF4-6C12K5D-C-LC
BF4-8C4K5D-C
BF4-8C11KD-C-LC
BF3-6C125D-N
BF3-6C900D-N
BF3-6C1K8D-N
BF3-6C6K0D-N-LC
BF3-8C1K5D-C
BF3-8C5K5D-C-LC
BF3-6C4K0D-N
BF3-6C10KD-N-LC
BF3-8C3K5D-C
BF3-8C9K0D-C-LC
BF3-6C8K0D-N
BF3-6C20KD-N-LC
BF3-8C7K0D-C
BF3-8C17KD-C-LC

TYPE DESCRIPTION

ANALOGUE:
BFx-yCppp-M-(zz)
DIGITAL:
BFx-yCpppD-M-(zz)

BF - band pass filter

x - frequency range

3 - VHF band III
(174-230 MHz)

4 - UHF band IV/V
(470-862 MHz)

yC - number of cavities

3C - 3 cavity filter

4C - 4 cavity filter

6C - 6 cavity filter

7C - 7 cavity filter

8C - 8 cavity filter

ppp - input power peak sync

pppD - input power rms

100 - up to 100 W

1K0 - up to 1 kW

10K - up to 10 kW

M - mask (for digital mode)

N - non-critical mask

C - critical mask

zz - cooling

without - conventional

HS - heat sink added

LC - liquid cooled

Specifications UHF filters 3-6 cavities up to 500 W p.s. / 100 W rms

	BF4-3C500	BF4-4C500 BF4-4C100D-N	BF4-6C500 BF4-6C100D-N
Frequency range	470 - 862 MHz		
Impedance	50 Ω		
Number of cavities	3	4	6
Band pass width	8 MHz CCIR / DTT		
Input power	500 W p.s. / 100 W rms		
Return loss (dB)	> 26		
Selectivity analogue (dB)*			
f0 -5,5 / +11 MHz	> 20	> 40	> 70
f0 -11 / +16,5 MHz	> 20	> 40	> 70
Insertion loss analogue (dB)*			
Center frequency (f0)	< 0,4	< 0,7	< 1,1
f vision (f0 - 2,75 MHz)	< 0,5	< 0,9	< 1,3
f sound (f0 + 2,25 MHz)	< 0,5	< 0,9	< 1,3
Selectivity digital (dB)*			
f0 ± 4,2 MHz	> 0,6	> 1,2	> 1,8
f0 ± 6 MHz	> 4	> 6,5	> 20
f0 ± 12 MHz	> 15	> 30	> 60
Insertion loss digital (dB)*			
Center frequency (f0)	< 0,41	< 0,71	< 1,32
f0 ± 3,805 MHz)	< 0,53	< 0,97	< 1,45
Temperature stability (kHz/K)*	15	16	16
Input and output connectors	N female / N female (default) SMA / N female		
Temperature range	From -5°C to +55°C		
Weight (kg)	1,5	2,0	3,0
Dimensions (mm)	177 x 46 x 103	221 x 46 x 103	280 x 46 x 103
Cooling	conventional heat sink		

* measured on mid-channel CH 45. Table corresponds to indicated return loss and flat response



BF4-3C500

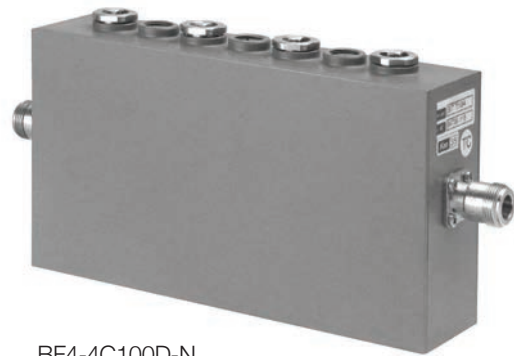

BF4-4C100D-N

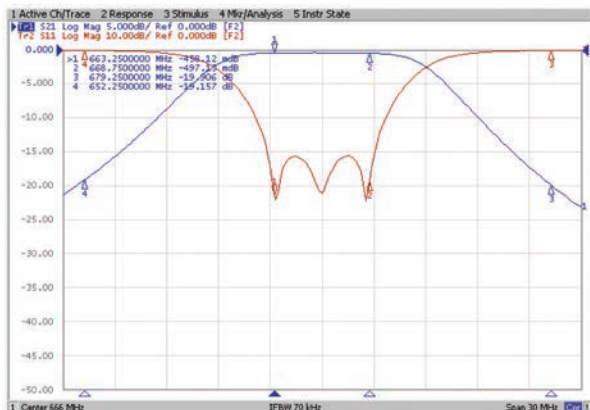

Insertion and Return loss BF4-3C500

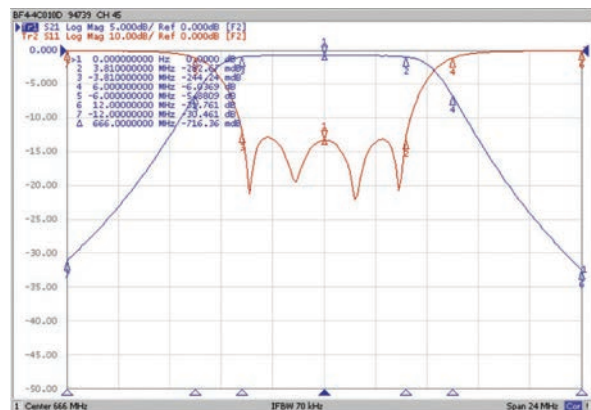

Insertion and Return loss BF4-4C100D-N

Specifications UHF filters 3-6 cavities up to 1 kW p.s. / 250 W rms

	BF4-3C1K0	BF4-4C1K0 BF4-4C250D-N	BF4-6C1K0 BF4-6C250D-N
Frequency range	470 - 862 MHz		
Impedance	50 Ω		
Number of cavities	3	4	6
Band pass width	8 MHz CCIR / DTT		
Input power	1 kW p.s. / 250 W rms		
Return loss (dB)	> 26		
Selectivity analogue (dB)*			
f0 -5,5 / +11 MHz	> 20	> 38	> 70
f0 -11 / +16,5 MHz	> 20	> 38	> 70
Insertion loss analogue (dB)*			
Center frequency (f0)	< 0,25	< 0,38	< 1,1
f vision (f0 - 2,75 MHz)	< 0,25	< 0,45	< 1,3
f sound (f0 + 2,25 MHz)	< 0,25	< 0,45	< 1,3
Selectivity digital (dB)*			
f0 ± 4,2 MHz	> 0,6	> 0,3	> 1,5
f0 ± 6 MHz	> 4	> 5,5	> 20
f0 ± 12 MHz	> 15	> 30	> 60
Insertion loss digital (dB)*			
Center frequency (f0)	< 0,41	< 0,38	< 1,1
f0 ± 3,805 MHz)	< 0,53	< 0,50	< 1,1
Temperature stability (kHz/K)*	14	15	15
Input and output connectors	DIN 7/16 female (default) EIA 7/8"		
Temperature range	From -5°C to +55°C		
Weight (kg)	6,0	6,8	10,5
Dimensions (mm)	320 x 84 x 170	401 x 84 x 170	560 x 84 x 170
Cooling	conventional heat sink		

* measured on mid-channel CH 45. Table corresponds to indicated return loss and flat response

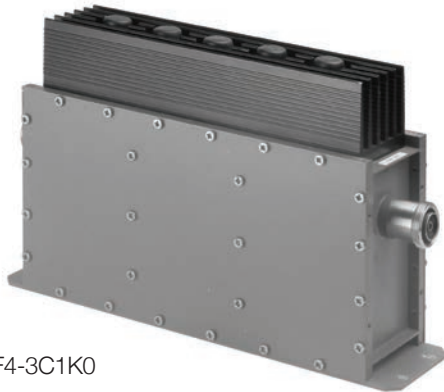

BF4-3C1K0

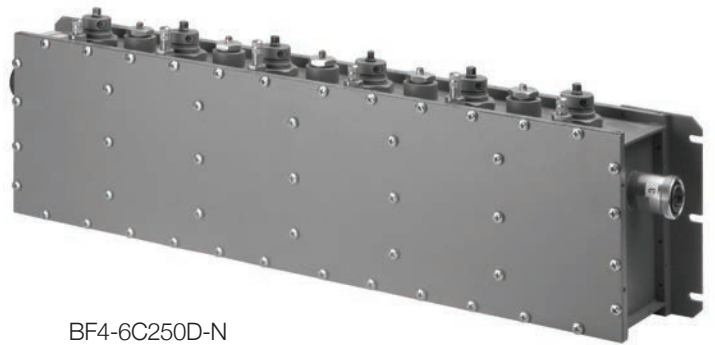

BF4-6C250D-N



Insertion and Return loss BF4-3C1K0

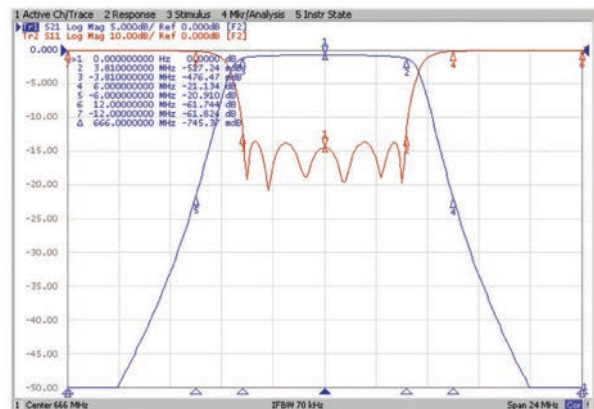

Insertion and Return loss BF4-6C250D-N

Specifications UHF filters 4 cavities up to 20 kW p.s.

	BF4-4C1K7 BF4-4C2K1-HS	BF4-4C3K5 BF4-4C4K0-HS BF4-4C13K-LC	BF4-4C7K0 BF4-4C9K0-HS BF4-4C20K-LC
Frequency range	470 - 862 MHz		
Impedance	50 Ω		
Number of cavities	4		
Band pass width	6 - 8 MHz CCIR		
Input power			
conventional cooling	1,7 kW p.s.	3,5 kW p.s.	7 kW p.s.
heat sink	2,1 kW p.s.	4 kW p.s.	9 kW p.s.
liquid cooling	/	13 kW p.s.	20 kW p.s.
Return loss (dB)	> 26		
Selectivity (dB)*			
f0 -5,5 / +11 MHz		> 40	
f0 -11 / +16,5 MHz		> 24	
Insertion loss (dB)*			
Center frequency (f0)	< 0,26	< 0,20	< 0,15
f vision (f0 - 2,75 MHz)	< 0,26	< 0,20	< 0,15
f sound (f0 + 2,25 MHz)	< 0,26	< 0,20	< 0,15
Harmonic attenuation			
up to 1,1 GHz	> 50	> 50	/
up to 3 GHz (with low-pass filter)		> 50	
Group delay variation (ns)		< 25	
Temperature stability (kHz/K)*		< 2	
Input and output connectors	DIN 7/16 f (default) EIA 7/8" EIA 1 5/8"	EIA 1 5/8" (default) EIA 3 1/8"	EIA 3 1/8" (default) EIA 4 1/2"
Temperature range	From -5°C to +55°C		
Weight (kg)	9,5	23	39
Dimensions (mm)	266 x 240 x 245	326 x 380 x 390	446 x 500 x 430
Cooling	conventional heat sink	conventional heat sink liquid (flow 6 l/min)	conventional heat sink liquid (flow 10 l/min)

* measured on mid-channel CH 45. Table corresponds to indicated return loss and flat response

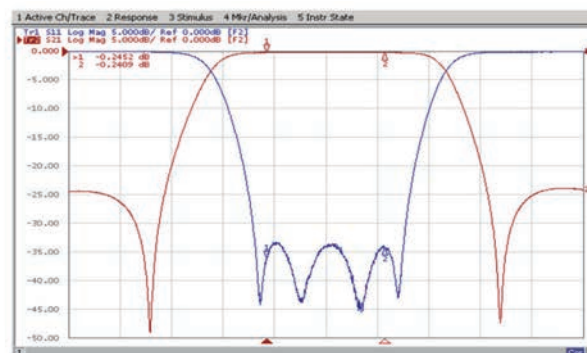

Insertion and Return loss for filters with non-critical mask