

# VHF yagi antennas

## TYPES

TA III/08-A

TA III/08-B

A ten element yagi designed antenna for high performance and long-term reliability, able to withstand severe climates such as ice, snow and slant spray. The TA III/08-A and TA III/08-B can accommodate the entire range of VHF frequencies.

The dipole and first director are housed in polyester radome. Clamps are used to mount the antenna on a tube (diameter 45 – 110 mm) and to enable easy changing of the polarisation from vertical to horizontal by swivel clamp.

Higher gain and beamed radiation patterns can be attained through a combination of two or more antennas.

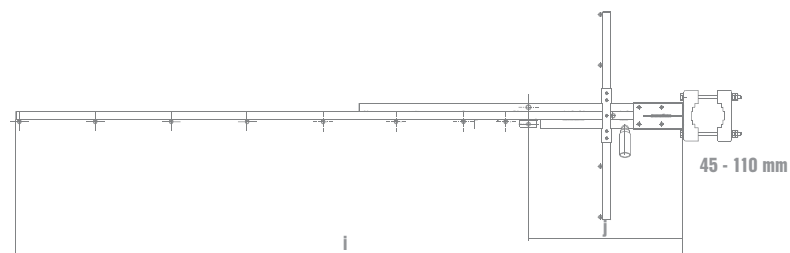
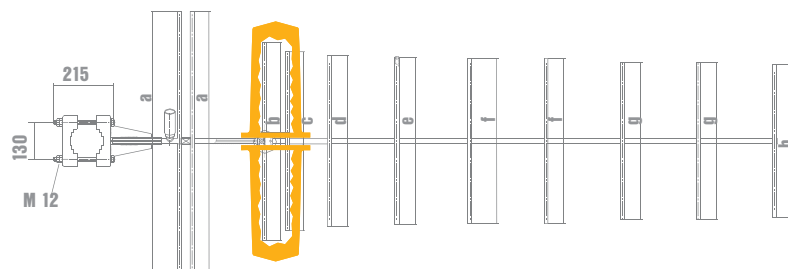
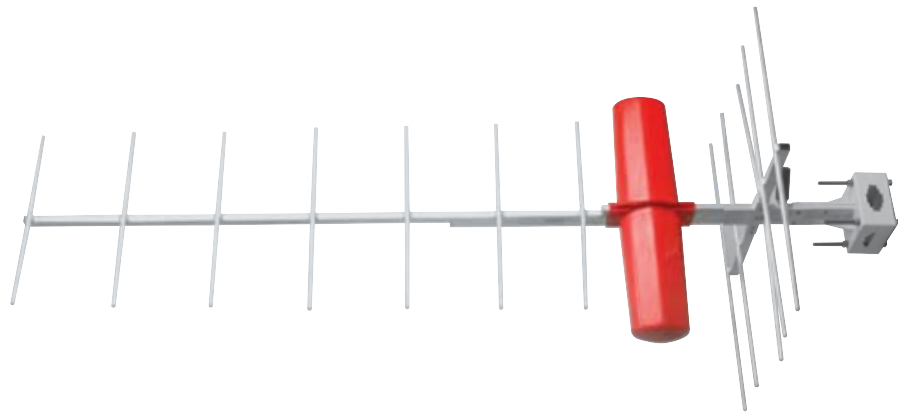

	a	b	c	d	e	f	g	h	i	j
TA III/08-A	920	702	634	605	595	585	560	540	2.370	548
TA III/08-B	800	616	550	526	517	510	486	470	2.100	508

## specifications

	TA III/08-A		TA III/08-B	
Input connector	N female			
Impedance	50 $\Omega$			
VSWR	$\leq 1,15$			
Frequency range	174 - 202 MHz		202 - 230 MHz	
Gain (ref. to half wave dipole)	8 - 10 dB		8,7 - 10,4 dB	
Polarization	horizontal or vertical			
Max. input power	500 W			
Radiation patterns at mid-band	horizontal	vertical	horizontal	vertical
- beam width at -3dB E plane	38 °	48 °	42 °	50 °
- beam width at -3dB H plane	48 °	38 °	50 °	42 °
Combinations	two or more antennas may be connected to attain higher gain and beamed radiation patterns			
Material	anodized aluminium stainless steel polyester			
Mounting	on tube 45 - 110 mm with swivel clamps			
Icing protection	dipole and first director are housed in a polyester radome			
Lightning protection	all metal parts of antenna are DC grounded			
Weight	13,5 kg		12,5 kg	
Wind load	750 N at 160 km/h			
Max. wind velocity	225 km/h			
Dimensions (mm)	2.370 x 920 x 730		2.100 x 800 x 650	

### radiation pattern

#### TA III/08-A

(at mid-band 188 MHz)

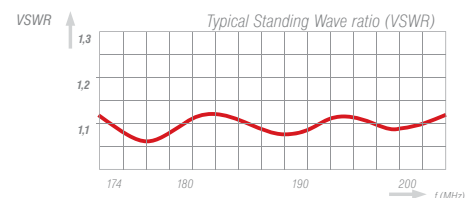
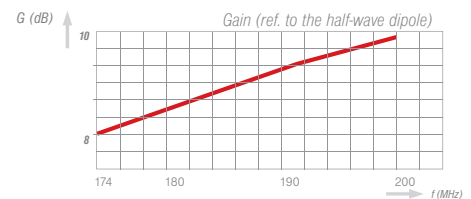
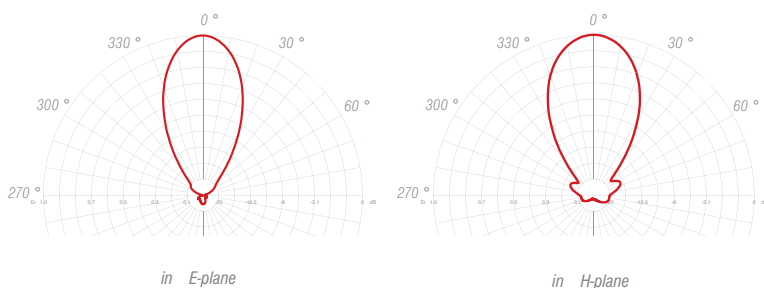

### radiation pattern

#### TA III/08-B

(at mid-band 216 MHz)

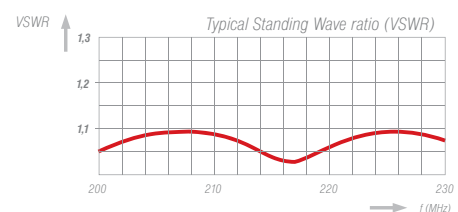
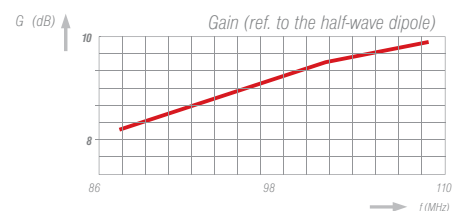
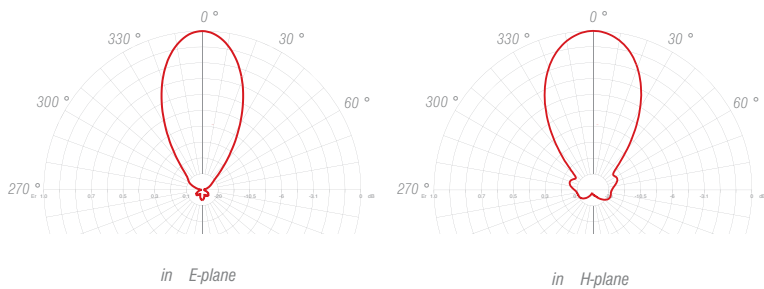

# VHF four field antenna panels

## TYPES

TA III/03 R

A VHF directional broadband antenna, the TA III/03 R is designed for horizontal or vertical polarised TV transmitting systems. Various antenna arrays can be assembled from TA III/03 R units from simple radiators to complex high-power antenna systems. They support different radiation patterns, whether omni-directional, horizontal non-directional, or customised radiation patterns.

The TA III/03 R consists of two aluminium dipoles with an inner conductor of silver plated brass. The dipole surface is finished with an anodised oxide layer, or painted. Hot dip galvanised steel is used for the reflector wall. The panel construction is easily mounted on the antenna masts using four M10 screws. Four field antenna is broadband for the entire VHF frequency band.

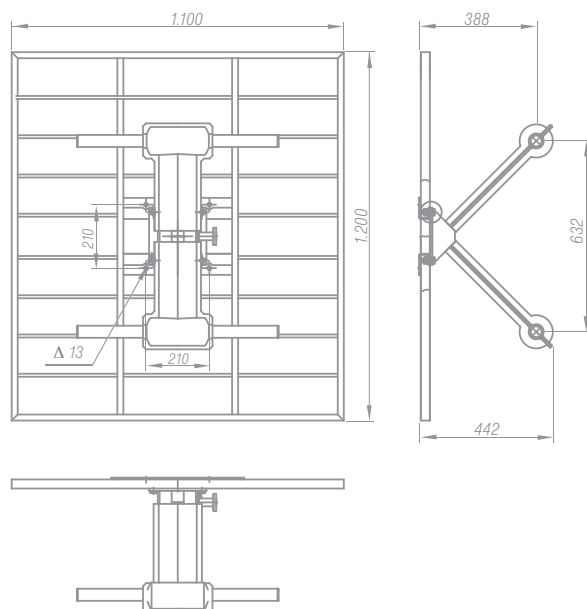

## specifications

		TA III/03 R	
Input connector	EIA 7/8" flange		
Impedance	50 $\Omega$		
VSWR	$\leq 1,15$		
Frequency range	174 - 230 MHz		
Gain (ref. to half wave dipole)	6,5 - 7,4 dB		
Polarization	horizontal or vertical		
Max. input power	5 kW		
Radiation patterns at mid-band - beam width at -3dB E plane - beam width at -3dB H plane	horizontal 62° 68°		vertical 68° 62°
Combinations	a certain number of identical panels can be associated so as to cover a determined geographic area		
Material - radiating dipoles, inner conductor - reflector wall - mounting clamps - radome	anodized aluminium, brass hot dip galvanized steel copper and brass polyester		
Mounting	4 holes for M10 mounting bolts		
Icing protection	an efficient anti-frost polyester protection covering at the center of the radiating dipoles		
Lightning protection	all metal parts of antenna are DC grounded		
Weight	18 kg		
Wind load	from the front side - 550 N at 160 km/h from side - 180 N at 160 km/h		
Max. wind velocity	225 km/h		
Dimensions (mm)	1.100 x 1.200 x 422		

## radiation pattern

### TA III/03 R

(at mid-band 210 MHz)

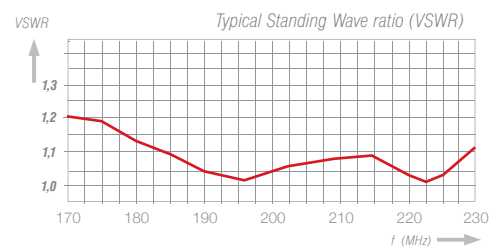
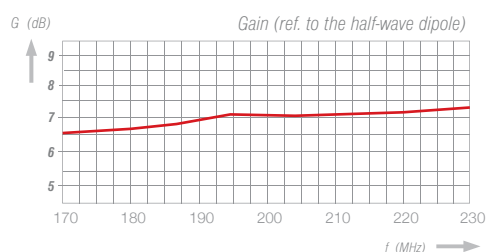
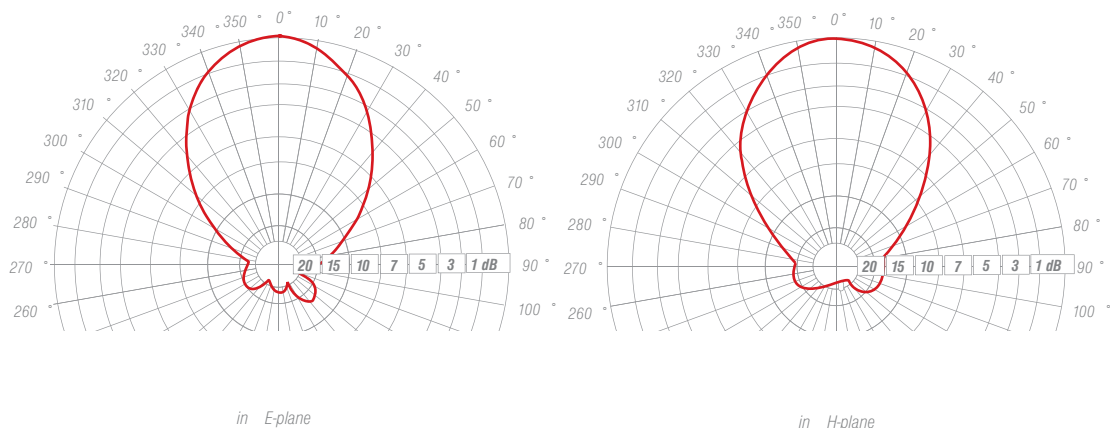

# VHF eight field antenna panels

## TYPES

### TAN III/10

The best professional antenna solution for systems that operate in extreme environments, featuring high gain value and broadband for the entire VHF frequency band.

Housed in protective polyester radome, the TAN III/10 is a VHF directional broadband antenna for horizontal polarised TV transmission systems whether omni-directional, non-directional or in customised radiation patterns.

Antenna panel is suitable for high power antenna systems, achieved by stacking in tiers. In such cases split system is used, which allows feeding of the antenna system with half power or even full transmitter power when only half antenna system is operating.

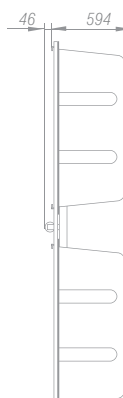
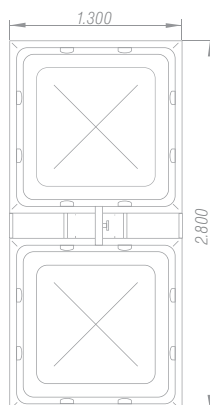
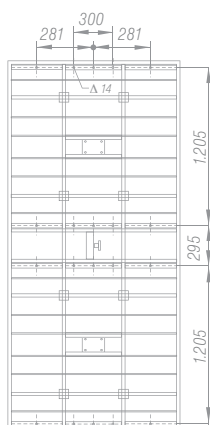

## specifications

	TAN III/10
Input connector	EIA 7/8" flange
Impedance	50 $\Omega$
VSWR	$\leq 1,15$
Frequency range	174 - 230 MHz
Gain (ref. to half wave dipole)	10,3 - 11,0 dB
Polarization	horizontal
Max. input power	5 kW
Radiation patterns at mid-band - beam width at -3dB E plane - beam width at -3dB H plane	62° 22°
Combinations	a certain number of identical panels can be associated so as to cover a determined geographic area
Material - reflector - radiating dipoles - feeders - radome	hot dip galvanized steel anodized aluminium copper and brass polyester
Mounting	4 consoles, each 5 holes, for M12 mounting bolts
Icing protection	The whole unit is protected against frosting and other atmospheric influences by a polyester coat
Lightning protection	all metal parts of antenna are DC grounded
Weight	135 kg
Wind load	3.200 N (wind speed at 150 km/h)
Max. wind velocity	225 km/h
Dimensions (mm)	1.300 x 2.800 x 640
Radome colours	red or white

## radiation pattern

### TAN III/10

(at mid-band 196 MHz)

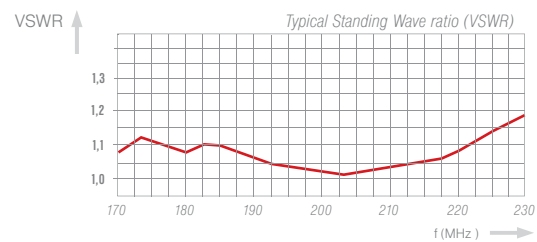
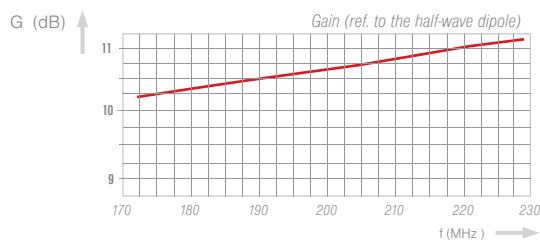
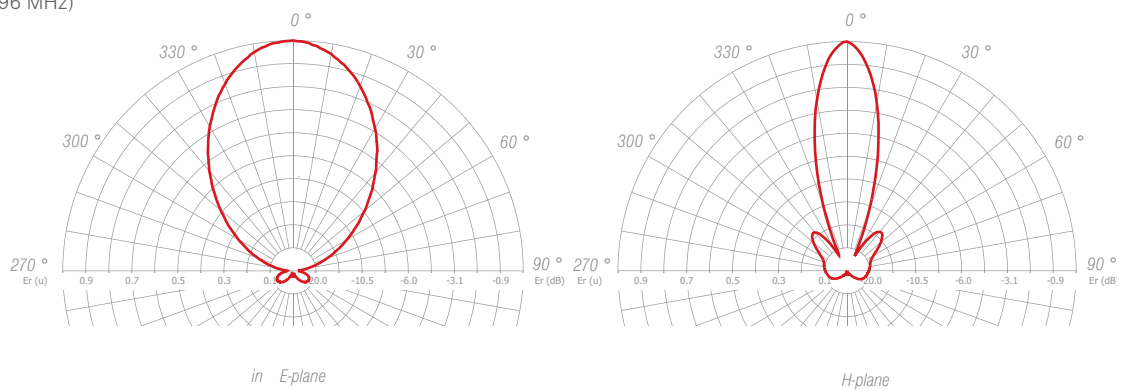

# UHF four field antenna panels

## TYPES

TVA 24/50

A UHF directional broadband antenna is designed for smaller horizontally or vertically polarised receiving and transmitting TV systems. Polarization of the system can be changed by rotating the panel 90°.

Antenna panel TVA 24/50 can be air-pressurized up to the dipoles. Antenna systems with this panel are designed with foam cables or even air cables.

Units can be assembled to provide omni-directional, horizontal non-directional or customised radiation patterns.

Protected by a robust polyester radome, it can operate in extreme weather conditions. The antenna is mounted on the antenna masts using four M8 mounting bolts. Mounting clamps for pipe towers available on request.

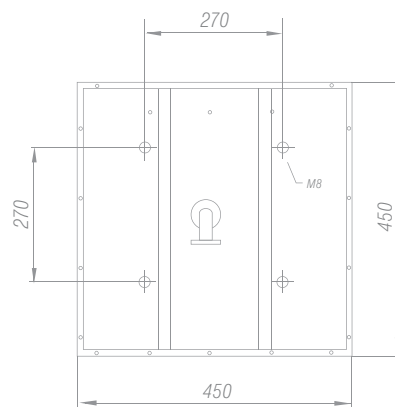
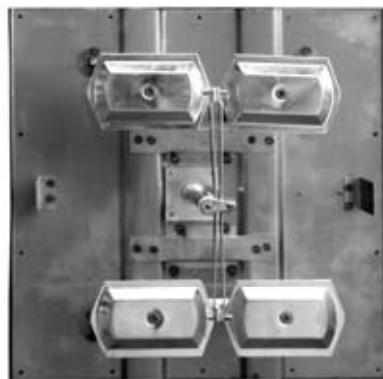

## specifications

		TVA 24/50	
Input connector	DIN 7/16 female or EIA 7/8" flange		
Impedance	50 $\Omega$		
VSWR	$\leq 1,2$		
Frequency range	470 - 862 MHz		
Gain (ref. to half wave dipole)	6,8 - 9,0 dB		
Polarization	horizontal or vertical		
Max. input power	1 kW (DIN 7/16 or EIA 7/8")		
Radiation patterns at mid-band	horizontal	vertical	
- beam width at -3dB E plane	56°	49°	
- beam width at -3dB H plane	49°	56°	
Combinations	this antenna is especially suitable as a component in arrays, with which various radiation patterns can be achieved		
Material	stainless steel		
- reflector screen and fittings	copper and brass with protection		
- dipoles and feeders	polyester		
- radome			
Mounting	4 holes for M8 mounting bolts		
Lightning protection	all metal parts of antenna are DC grounded		
Weight	6,2 kg		
Wind load	from the front side - 307 N at 160 km/h from side - 150 N at 160 km/h		
Max. wind velocity	225 km/h		
Dimensions (mm)	450 x 450 x 225		
Radome colours	red or white or grey		
Note	When using this antenna panel for air-pressurized antenna system, we recommend to order panel with connector EIA 7/8" to avoid air leakage.		

## radiation patterns

### TVA 24/50

in E-plane

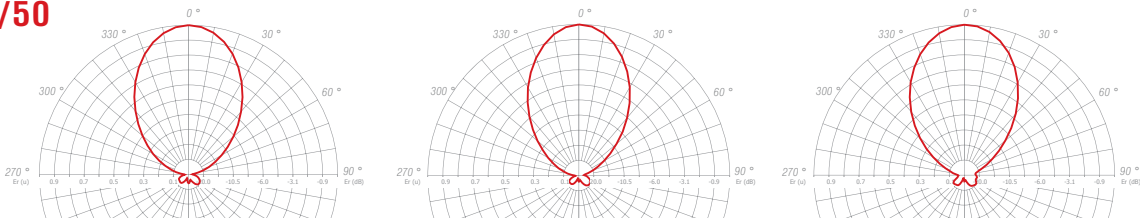

## radiation patterns

### TVA 24/50

in H-plane

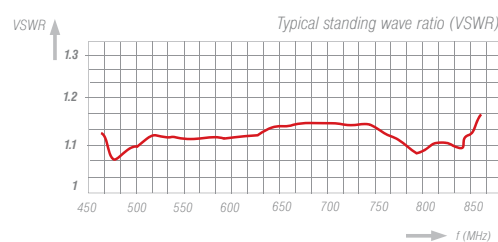
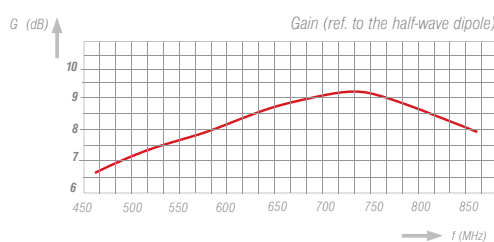
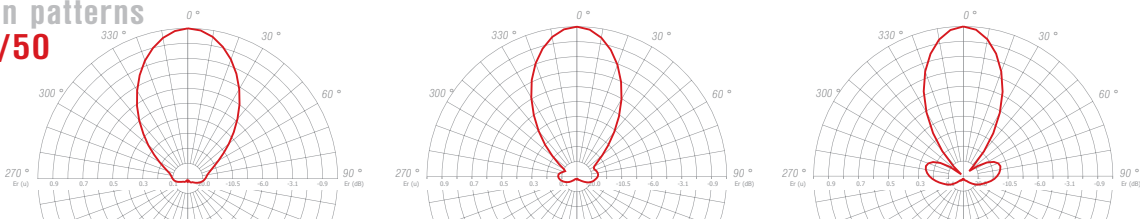

# UHF eight field antenna panels

## TYPES

TVA 31/50

TVA 51/50

UHF directional broadband antenna panels TVA 31/50 and TVA 51/50 are designed for horizontal or vertical polarization used mainly for transmitting TV systems. Units can be assembled to provide omni-directional, horizontal non-directional or customised radiation patterns.

Protected by a robust polyester radome, these panels can operate in extreme weather conditions. Every panel is factory tested to 55 kPa air-pressure. Pressurization to the dipole end makes it possible to use these panels in air-pressurized antenna systems as well in systems designed with foam cables.

Both antenna panels are suitable for high power antenna systems, achieved by stacking in tiers. In such cases split system is used, which allows feeding of the antenna system with half power or even full transmitter power when only half antenna system is operating.

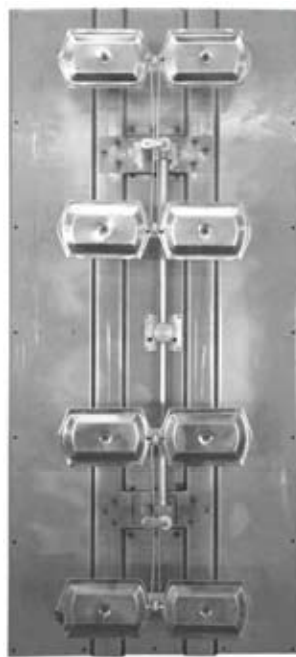

TVA 31/50



TVA 51/50

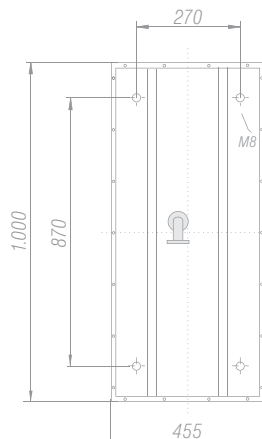
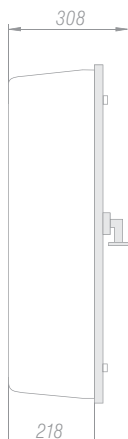

## specifications

	TVA 31/50	TVA 51/50
Input connector	DIN 7/16 female or EIA 7/8" flange	
Impedance	50 $\Omega$	
VSWR	$\leq 1,12$	$\leq 1,12$
Frequency range	470 - 862 MHz	
Gain (ref. to half wave dipole)	10,2 - 12,0 dB	10,2 - 11,0 dB
Polarization	horizontal	vertical
Max. input power	1 kW (DIN 7/16); 2,5 kW (EIA 7/8")	
Radiation patterns at mid-band - beam width at -3dB E plane - beam width at -3dB H plane	60° 20°	20° 60°
Combinations:	this antenna is especially suitable as a component in arrays, with which various radiation patterns can be achieved	
Material - reflector screen and fittings - dipoles and feeders - radome	stainless steel copper and brass with protection polyester	
Mounting	4 holes for M8 mounting bolts	
Lightning protection	all metal parts of antenna are DC grounded	
Weight	12,5 kg	
Wind load	from the front side - 675 N at 160 km/h from side - 350 N at 160 km/h	
Max. wind velocity	225 km/h	
Dimensions (mm)	1.000 x 455 x 225	
Radome colours	red or white or grey	
Note	When using this antenna panel for air-pressurized antenna system, we recommend to order panel with connector EIA 7/8" to avoid air leakage.	

## radiation patterns

## TVA 31/50

at mid-band 660MHz

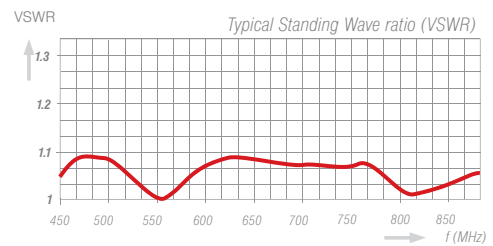
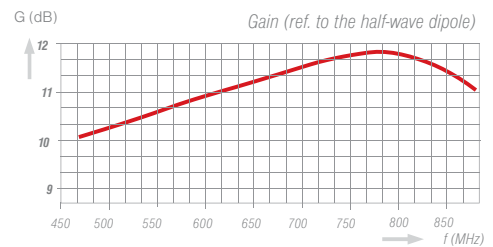
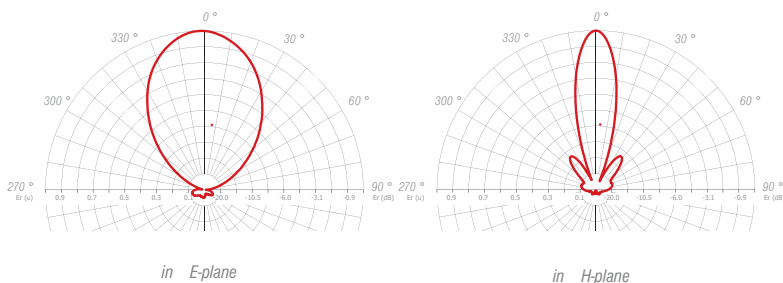

## radiation patterns

## TVA 51/50

at mid-band 660MHz

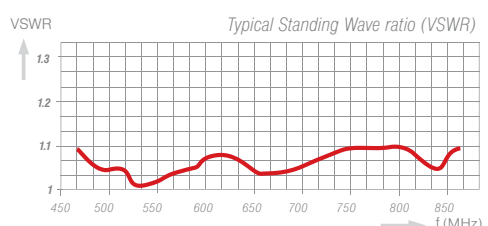
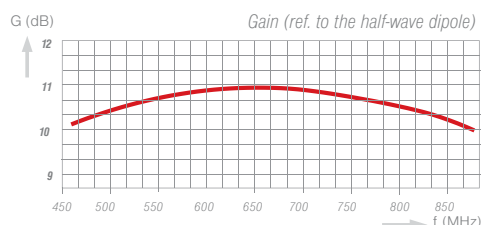
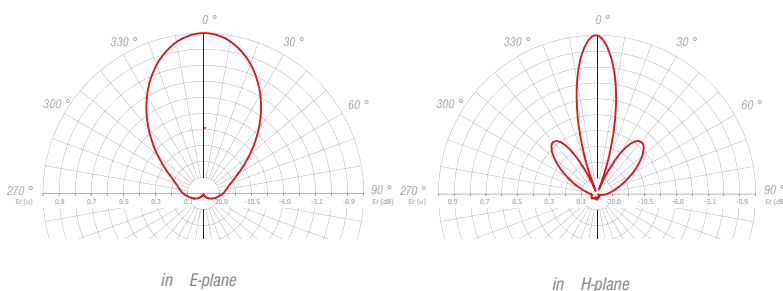

# UHF log - periodic antennas

## TYPES

LAP 4/5-50/16

A compact and hard-wearing receiving and transmitting antenna LAP 4/5-50/16 is designed to withstand extreme environments, and especially suited to the beam-width and front/back ratio of pipe masts.

A combination of two or more antennas can be employed to achieve higher gain and beamed radiation patterns. Swivel mounting clamp enables easy changing of polarization.

Antenna is broadband for the entire UHF frequency band.

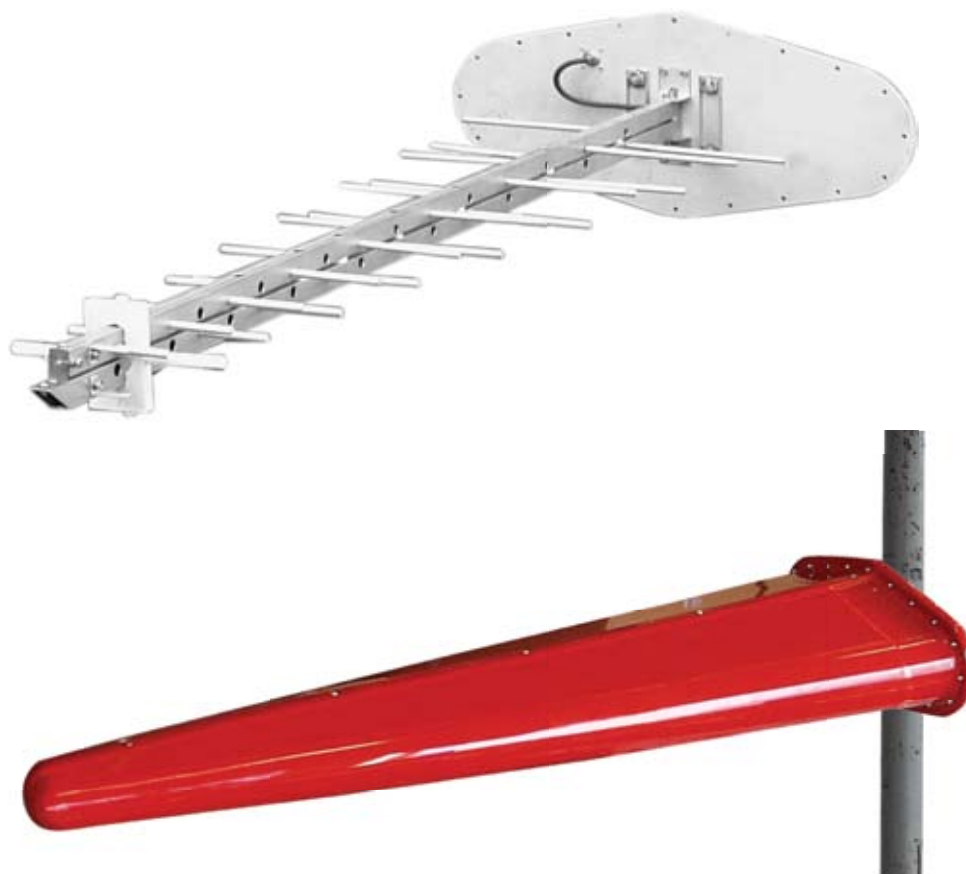

TOP VIEW IN HORIZONTAL polarization



TOP VIEW IN VERTICAL polarization

## specifications

log - periodic antenna LAP 4/5-50/16		
Input connector	N female, DIN 7/16 female	
Impedance	50 $\Omega$	
VSWR	$\leq 1,2$	
Frequency range	470 - 862 MHz	
Gain (ref. to half wave dipole)	8,7 - 9,5 dB	
Polarization	horizontal or vertical	
Max. input power	100 W	
Radiation patterns at mid-band - beam width at -3dB E plane - beam width at -3dB H plane	horizontal 44 ° 52 °	vertical 52 ° 44 °
Combinations	two or more antennas may be connected to attain higher gain and radiation patterns with very high side-lobe suppression	
Material - reflector screen and fittings - dipoles and feeders - radome	anodised aluminium stainless steel polyester	
Mounting	to pipes of 40 - 60 mm diameter by means of mounting clamps included	
Lightning protection	all metal parts of antenna are DC grounded	
Weight	6,5 kg	
Wind load (at 160 km/h): - for horizontal polarization: - for vertical polarization:	frontal/lateral: 63 / 102 N frontal/lateral: 63 / 500 N	
Max. wind velocity - for horizontal polarization: - for vertical polarization:	180 km/h 180 km/h	
Dimensions (mm)	450 x 1.220 x 130	
Radome colours	red	

## radiation patterns

in E-plane

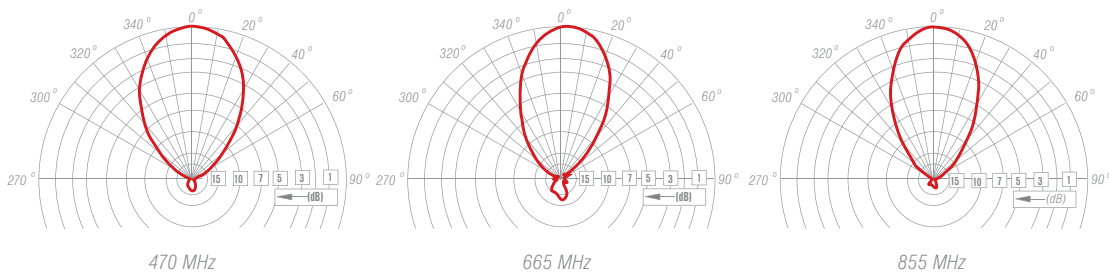

## radiation patterns

in H-plane

